



## COORDINATI collection

INFO TECNICHE	pag.	859
TABELLA PREZZI FINITURE	pag.	860
RICAMBI	pag.	875



CONSULTA LISTINO ON LINE  
CHECK ON LINE PRICE LIST

[www.bellostarubinetterie.com/online/42\\_btronic.pdf](http://www.bellostarubinetterie.com/online/42_btronic.pdf)

# B-TRONIC - RUBINETTI ELETTRONICI

EQB DESIGN

## B TRONIC: ELETTRONICA AD ALTA TECNOLOGIA

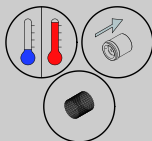

1) Gruppo elettrovalvola con regolazione della temperatura, valvole di non ritorno e filtri incorporati.  
1) Electro valve group with temperature regulator, no came back valve and built-in filters.



2) Gruppo batterie al litio incluse.  
2) Lithium group batteries included.



3) Trasformatore di rete per alimentazione rete fissa opzionale.  
3) Transformer for power supply optional.



4) Gruppo infrarossi programmabile con powersaving (alla accensione il sistema chiude la valvola e verifica lo stato di accescamento o meno del sensore):

A\_ Sensore non e' accecato (alimentazione da trasformatore) il sistema esegue i seguenti parametri:

- tempo di check (frequenza d'impulso): 6 impulsi al secondo  
- antivandalo: 20s (tempo di costante permanenza accescamento)  
- comfort time: 10s (tempo di ritardo chiusura valvola dall'ultimo rilascio di accescamento).

B\_ Sensore e' accecato (alimentazione da batteria/powersaving) il sistema mostra a mezzo della accensione di un led il riconoscimento di tale richiesta ed in seguito esegue i seguenti parametri:

- tempo di check 1: 6 impulsi al secondo, per un tempo massimo di circa 1h30, successivamente interviene check 2.

- tempo di check 2: 3 impulsi al secondo, si torna al check1 alla prima verifica accescamento. check2 e' lo stato di risparmio energetico.

- antivandalo: 20s (tempo di costante permanenza accescamento)  
- comfort time: 10s (tempo di ritardo chiusura valvola dall'ultimo rilascio di accescamento).

4) IR group program by powersaving (at start the system close the valve and verify the counter sinked or not of the sense):

A\_ The sense is not counter sinked (supply by transformer) the system makes these parameters:

- check time (impulse frequency): 6 impulses at second  
- no vandal proof: 20s (steady time of counter sinked)  
- comfort time: 10s (delay time of closed valve from the last time of counter sinked).

B\_ The sense is counter sinked (supply by battery/powersaving) the system shows by led ignition this request and then makes these parameters:

- time check 1: 6 impulses for a maximum time of 1h30, then goes to check 2

- time check 2: 3 impulses, come back to check 1 at the first verify of counter sinked. Check 2 is the mode of energy saving  
- no vandal proof: 20s (steady time of counter sinked)

- comfort time: 10s (delay time of closed valve from the last time of counter sinked).

## B TRONIC: HIGH TECHNOLOGY ELECTRONIC



5) Compensazione algoritmica di risposta sensore alla repentina variazione di temperatura locale.  
5) Algorithm compensation of sense reply of the local temperature variation.



6) Protezione alla inversione di polarità delle batterie.  
6) Care for the reversing polarity of batteries.



7) Protezione al cortocircuito driver valvola.  
7) Care for the short circuit of driver valve.



8) Quando le batterie devono essere sostituite la valvola si blocca in modalità chiusa. Ad ogni successiva richiesta utente il LED interno al sensore lampeggerà velocemente senza che la valvola venga più aperta fino al cambio batterie.

8) When the batteries have to be supplanted, the valve is on closed way. From now at new request from anyone the internal LED sense will flash quickly free till the valve it will be open till the battery change.



9) Distanza di sensing lineare: 100mm +/- 20mm.

9) Distance sensing line: 100mm +/- 20mm.



10) Sensing a 100mm: -1.8mm + 1.8mm.

10) Sensing a 100mm: -1.8mm + 1.8mm.



11) Temperatura operativa: da un minimo di -10C ad un massimo di +60C.

11) Operator temperature: from less -10C than max +60C.



12) Sensore adatto a qualunque condizione d'illuminamento artificiale e/o naturale.

12) Useful sense for any light natural or not condition.

Prodotti elettronici certificati  
Electronic products certified



## PROGETTO SU MISURA: RICHIESTE SPECIALI

I tecnici di Bellosta Rubinetterie sono, inoltre, a disposizione di architetti e designers, per offrire un servizio esclusivo: personalizzazioni di elementi in funzione di specifiche richieste estetiche o problematiche legate a vincoli progettuali, verifica della fattibilità attraverso opportuni studi CAD e sviluppo del disegno tecnico del prodotto speciale richiesto.

Per informazioni e richieste PROGETTI SU MISURA:  
ufficiotecnico@bellostarubinetterie.com

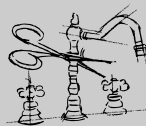

progetto

"sumisura"

## PROGETTO SU MISURA: SPECIAL REQUESTS

Engineers Bellosta Rubinetterie are also available to architects and designers, to offer an exclusive service: customizations of items according to specific aesthetic requirements or issues related to design constraints, verification of the feasibility studies and development through appropriate CAD technical design the required special product. For information and requests "SU MISURA" PROJECTS:  
ufficiotecnico@bellostarubinetterie.com



B-TRONIC

**PREZZO FINITURE**

Calcola il prezzo di listino (IVA esclusa) delle finiture diverse dal cromato, consultando la seguente tabella.

Moltiplicare il **PREZZO LISTINO** per il **COEFFICIENTE MOLTIPLICATORE** della finitura scelta, arrotondando per difetto il prezzo ottenuto (eliminare i centesimi).  
**ESEMPIO** per ordinare art. 0405/S/EL in finitura dorato: codice 04-0405/S/EL

**PRICE FINISHES**

Include the list price (excluding VAT) of different finishes from chrome, consulting the following table. Multiply the **PRICE LIST COEFFICIENT MULTIPLIER** of the chosen finish, reducing the price obtained by deleting the centesim.

**EXAMPLE** to order art. 0405/S/EL gold finish: code 04-0405/S/EL

**MOLTIPLICATORI FINITURE DI SERIE  
 STANDARD FINISHES MULTIPLIERS**

COD. CODE	DESCRIZIONE FINITURA FINISH DESCRIPTION	BAMBU'	FUNTANIN FUNTANIN BJOUX	ZEHN	EDWARD
01-	cromato/chrome				

PREZZO LISTINO°

**MOLTIPLICATORI FINITURE A RICHIESTA  
 ON REQUEST FINISHES MULTIPLIERS**

COD. CODE	DESCRIZIONE FINITURA FINISH DESCRIPTION	BAMBU'	FUNTANIN FUNTANIN BJOUX	ZEHN	EDWARD
02-	cromo/oro/chrome/gold				
03-	oro/argento/gold/silver				
04-	dorato/gold				
05-	bronzo satinato/satin bronze				
06-	rame vecchio/old copper				
07-	vecchio argento/old silver				
08-	canna di fucile/gun barrel				
10-	verderame/verdigris				
11-	nero antracite/anthracite black				
12-	ottone lucido/polished brass				
13-	ottone naturale/natural brass				
14-	bianco lucido/glossy white				
19-	nero lucido/glossy black				
28-	nickel satinato/satin nickel				
30-	nickel lucido/polished nickel				
33-	cromo satinato/satin chrome				
34-	cromo spazzolato/brushing chrome				
35-	nickel spazzolato/brushing nickel				
56-	avorio/ivory				
57-	azzurro/light blue				
58-	verdino/light green				

**COMPOSIZIONE CODICE PER ORDINARE ARTICOLO IN FINITURA**

**XX** - **0405/S/EL**

CODICE FINITURA  
FINISH CODE

CODICE ARTICOLO  
ITEM NUMBER

**MOLTIPLICATORI FINITURE A RICHIESTA  
 ON REQUEST FINISHES MULTIPLIERS**

COD. CODE	DESCRIZIONE FINITURA FINISH DESCRIPTION	BAMBU'	FUNTANIN FUNTANIN BJOUX	ZEHN	EDWARD
59-	marrone/brown				
60-	arancio/orange				
61-	rosso/red				
66-	bianco opaco/matt white				
67-	nero opaco/matt black				
68-	rame opaco/matt copper				
69-	argento opaco/matt silver				
71-	oro opaco/matt gold				
72-	bronzo opaco/matt bronze				
75-	dorato spazzolato/brushing gold				
87-	oro rosa/pink gold				
88-	ottone sisal/sisal brass				
89-	industrial				
92-	pomice opaco/matt pumice				
93-	arenaria opaco/matt sandstone				
94-	tuscany spazzolato/brushing tuscany				
95-	rame acidato/etched copper				
96-	cemento opaco/matt cement				
A1-	brina opaco/matt frost				
A2-	tuscany cerato/oilskin tuscany				
A3-	ottone acidato/etched brass				
A4-	basalto opaco/matt basalt				
B2-	black gun metal PVD				
B3-	nickel PVD				
B4-	matt gold PVD				

°PREZZO DI LISTINO PRICE LIST

\* N.R. = NON REALIZZABILE NOT MADE

RICH. = PREZZO A RICHIESTA ON REQUEST PRICE



## 0405/S/EL | BAMBU'

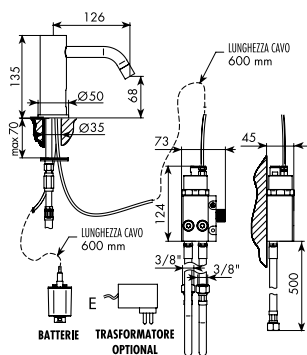

### MISCELATORE CON ATTIVATORE INFRAROSSO LAVABO BASIN MIXER WITH INFRARED ACTIVATOR

- > attivatore ad infrarosso con campo di azione da 80 a 120mm
- > interasse bocca 126
- > impostazione temperatura manuale
- > gruppo elettrovalvole incluso
- > pacchetto batterie incluso
- > gestione con trasformatore per corrente opzionale: art. 755056
- > flessibili di alimentazione > senza scarico



CROMATO	ALTRE FINITURE
01-0405/S/EL €	XX-0405/S/EL € x M*



01- cromato / XX- finitura

## 8305/S/EL | FUNTANIN BIJOUX

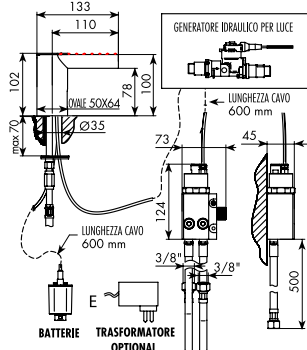

### MISCELATORE CON ATTIVATORE INFRAROSSO LAVABO C/SWAROVSKI BASIN MIXER WITH INFRARED ACTIVATOR WITH SWAROVSKI

- > attivatore ad infrarosso con campo di azione da 80 a 120mm
- > interasse bocca 110
- > impostazione temperatura manuale
- > gruppo elettrovalvole incluso
- > pacchetto batterie incluso
- > gestione con trasformatore per corrente opzionale: art. 755056
- > luce a LED incorporata con variazione in base alla temperatura
- > uscita libera senza areatore
- > flessibili di alimentazione > senza scarico
- > bocca con SWAROVSKI



CROMATO	ALTRE FINITURE
01-8305/S/EL €	XX-8305/S/EL € x M*

## 8105/S/EL | FUNTANIN

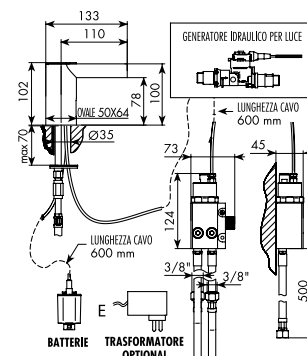

### MISCELATORE CON ATTIVATORE INFRAROSSO LAVABO BASIN MIXER WITH INFRARED ACTIVATOR

- > attivatore ad infrarosso con campo di azione da 80 a 120mm
- > interasse bocca 110
- > impostazione temperatura manuale
- > gruppo elettrovalvole incluso
- > pacchetto batterie incluso
- > gestione con trasformatore per corrente opzionale: art. 755056
- > luce a LED incorporata con variazione in base alla temperatura
- > uscita libera senza areatore
- > flessibili di alimentazione > senza scarico



CROMATO	ALTRE FINITURE
01-8105/S/EL €	XX-8105/S/EL € x M*

## 7505/N/S/EL | ZEHN

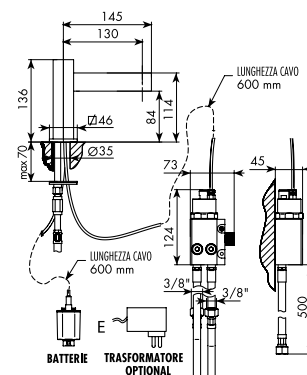

### MISCELATORE CON ATTIVATORE INFRAROSSO LAVABO BASIN MIXER WITH INFRARED ACTIVATOR

- > attivatore ad infrarosso con campo di azione da 80 a 120mm
- > interasse bocca 130
- > impostazione temperatura manuale
- > gruppo elettrovalvole incluso
- > pacchetto batterie incluso
- > gestione con trasformatore per corrente opzionale: art. 755056
- > flessibili di alimentazione
- > senza scarico



CROMATO	ALTRE FINITURE
01-7505/N/S/EL €	XX-7505/N/S/EL € x M*



## 0805/4/S/EL | EDWARD

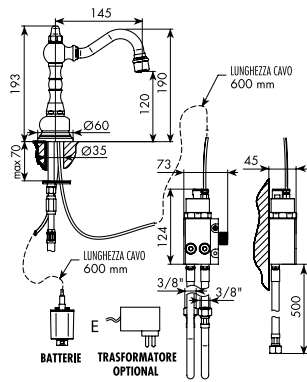

### MISCELATORE CON ATTIVATORE INFRAROSSO LAVABO BASIN MIXER WITH INFRARED ACTIVATOR

- > attivatore ad infrarosso con campo di azione da 80 a 120mm
- > interasse bocca 130
- > impostazione temperatura manuale
- > gruppo elettrovalvole incluso
- > pacchetto batterie incluso
- > gestione con trasformatore per corrente opzionale: art. 755056
- > flessibili di alimentazione
- > senza scarico



0136/U p. 880



0133/L p. 879

#### CROMATO

01-0805/4/S/EL €

#### ALTRE FINITURE

XX-0805/4/S/EL € x M\*



034013

01- cromato / XX- finitura

## 0421/EL/E + 045175 | BAMBU'

NEW

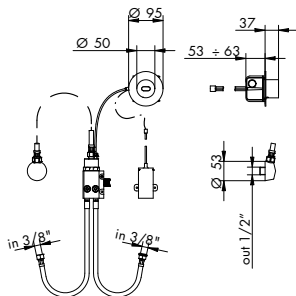

### MISCELATORE REMOTO CON ATTIVATORE INFRAROSSO LAVABO REMOTE BASIN MIXER WITH INFRARED ACTIVATOR

- > attivatore ad infrarosso con campo di azione da 80 a 120 mm
- > impostazione temperatura manuale
- > gruppo elettrovalvole incluso
- > pacchetto batterie incluso
- > gestione con trasformatore per corrente opzionale: art. 755056
- > senza scarico
- > piastra tonda



0136/U p. 880



0133/L p. 879

#### PARTI ESTERNE - CROMATO

01-0421/EL/E €

#### PARTI ESTERNE - ALTRE FINITURE

XX-0421/EL/E € x M\*

#### PARTE INCASSO

045175 €

PREZZO TOTALE €

**ABBINAMENTI CONSIGLIATI BOCHE LAVABO:**  
PER SOLUZIONI ALTERNATIVE E LISTINO PREZZI, CONSULTARE  
LE COLLEZIONI DI RIFERIMENTO

**SUGGESTED BASIN SPOUT:**  
FOR ALTERNATIVE SOLUTIONS AND PRICE LIST, SEE THE  
COLLECTIONS



**464008 LIKE**  
BOCCA LAVABO DA PARETE  
WALL BASIN SPOUT



**484003 JEANS**  
BOCCA LAVABO DA PARETE  
WALL BASIN SPOUT



**4605/1/C LIKE**  
BOCCA MONOFORO GIREVOLE  
SWINGING BASIN SPOUT



**0405/26 BAMBU'**  
BOCCA LAVABO DA PAVIMENTO  
FLOOR BASIN SPOUT



**894019 STILLE**  
BOCCA LAVABO DA PARETE  
WALL BASIN SPOUT

## 0421/Q/EL/E + 045175 | BAMBU'

NEW

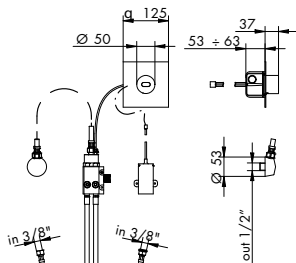

### MISCELATORE REMOTO CON ATTIVATORE INFRAROSSO LAVABO REMOTE BASIN MIXER WITH INFRARED ACTIVATOR

- > attivatore ad infrarosso con campo di azione da 80 a 120 mm
- > impostazione temperatura manuale
- > gruppo elettrovalvole incluso
- > pacchetto batterie incluso
- > gestione con trasformatore per corrente opzionale: art. 755056
- > senza scarico
- > piastra quadra



6536/U p. 884



6533 p. 879

#### PARTI ESTERNE - CROMATO

01-0421/Q/EL/E €

#### PARTI ESTERNE - ALTRE FINITURE

XX-0421/Q/EL/E € x M\*

#### PARTE INCASSO

045175 €

PREZZO TOTALE €

**ABBINAMENTI CONSIGLIATI BOCHE LAVABO:**  
PER SOLUZIONI ALTERNATIVE E LISTINO PREZZI, CONSULTARE  
LE COLLEZIONI DI RIFERIMENTO

**SUGGESTED BASIN SPOUT:**  
FOR ALTERNATIVE SOLUTIONS AND PRICE LIST, SEE THE  
COLLECTIONS



**794004 B-UNO/B-DUE**  
BOCCA LAVABO DA PARETE  
WALL BASIN SPOUT



**484011 JEANS/JQ**  
BOCCA LAVABO DA PARETE  
WALL BASIN SPOUT



**7505/N1/C ZEHN**  
BOCCA LAVABO MONOFORO ALTA  
HIGHER WASH SPOUT



**7705/26 BEETHOVEN**  
BOCCA LAVABO DA PAVIMENTO  
FLOOR BASIN SPOUT



**794019 STILLE**  
BOCCA LAVABO DA PARETE  
WALL BASIN SPOUT

## 1321/K/EL/E + 045175 | EDWARD

NEW

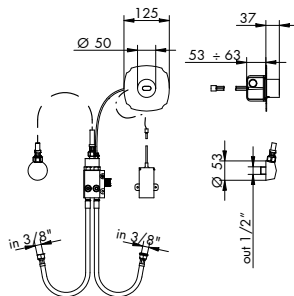

### MISCELATORE REMOTO CON ATTIVATORE INFRAROSSO LAVABO REMOTE BASIN MIXER WITH INFRARED ACTIVATOR

- > attivatore ad infrarosso con campo di azione da 80 a 120 mm
- > impostazione temperatura manuale
- > gruppo elettrovalvole incluso
- > pacchetto batterie incluso
- > gestione con trasformatore per corrente opzionale: art. 755056
- > senza scarico
- > piastra classic



0136/U p. 880



0133/L p. 879

#### PARTI ESTERNE - CROMATO

01-1321/K/EL/E €

#### PARTE INCASSO

045175 €

PREZZO TOTALE €

#### PARTI ESTERNE - ALTRE FINITURE

XX-1321/K/EL/E € x M\*

**ABBINAMENTI CONSIGLIATI BOCHE LAVABO:**  
PER SOLUZIONI ALTERNATIVE E LISTINO PREZZI, CONSULTARE  
LE COLLEZIONI DI RIFERIMENTO

**SUGGESTED BASIN SPOUT:**  
FOR ALTERNATIVE SOLUTIONS AND PRICE LIST, SEE THE  
COLLECTIONS



**084057 EDWARD**  
BOCCA LAVABO DA PARETE  
WALL BASIN SPOUT



**174014 STRESA**  
BOCCA LAVABO DA PARETE  
WALL BASIN SPOUT



**144017 STILLE**  
BOCCA LAVABO DA PARETE  
WALL BASIN SPOUT

## 755056



### TRASFORMATORE PER KIT IR TRANSFORMER FOR IR KIT

#### SENZA FINITURA

755056 €